

REV.	ECN NO.	LOCATIONS	DESCRIPTION	DATE	CHANGER

NOTE:

1. MATERIAL:

- a. HOUSING: PBT GLASS FIBRE UL94 V-0 ; WHITE
- b. CONTACT: BRONZE T=0.25±0.02mm
(SURFACE PLATING: Au1u" + Sn80~100u" + Ni60u")
- c. SHEEL: BRONZE T=0.30±0.02mm
(SURFACE PLATING: Cu80u"~100u" Ni100u"~120u")

2. ELECTRIC:

- a. CONTACT RESISTANCE: 30 MILLIOHMS MAX
- b. INSULATION RESISTANCE: 1000 MEGA OHMS MIN
- c. DIELECTRIC VOLTAGE: 500V AC ONE SEC LEVEL
- d. OPERATING TEMPERATURE: -55°C~85°C

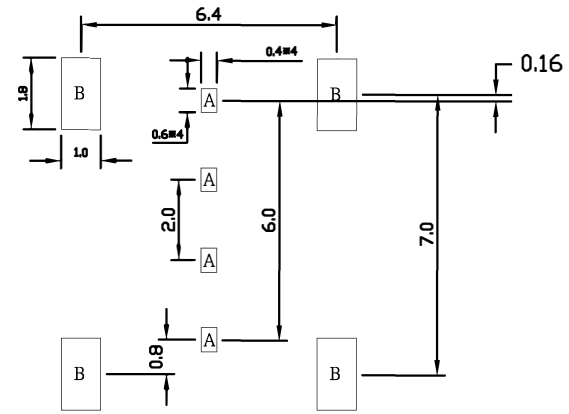
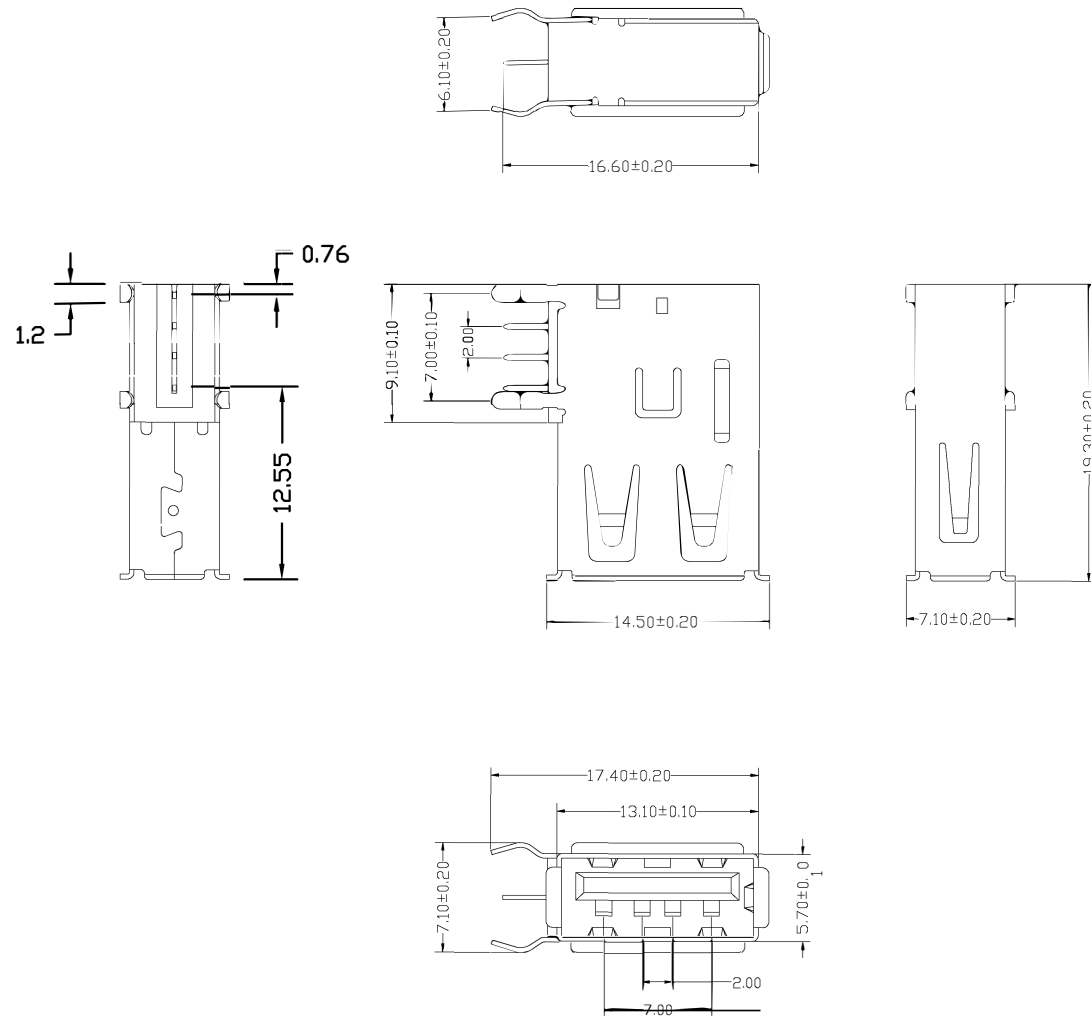

TUB-1F 04 1 1 -1

① ② ③ ④ ⑤

- ① Series No.
- ② Plating code:
1F= Gold flash
- ③ No. of Contact:
- ④ OTHER OPTIONS:
1=STANDART
- ⑤ PACKING
1= Packing

UNLESS OTHERWISE SPECIFIED TOLERANCE							
ANG	TOL	DIM	TOL(1)	TOL(2)	TOL(3)	TOL(4)	TOL(5)
0~5	±0.1	0~1	±0.015	±0.02	±0.03	±0.05	±0.10
10~20	±0.2	1~3	±0.02	±0.03	±0.05	±0.08	±0.13
20~40	±0.3	3~6	±0.03	±0.05	±0.08	±0.10	±0.15
40~60	±0.5	6~12	±0.05	±0.08	±0.10	±0.13	±0.18
60~90	±0.8	12~18	±0.08	±0.10	±0.13	±0.15	±0.20
90~120	±1.0	18~34	±0.10	±0.13	±0.15	±0.18	±0.25
120~150	±1.5	34~50	±0.13	±0.15	±0.18	±0.20	±0.30
150~180	±1.8	50~100	±0.15	±0.18	±0.20	±0.25	±0.35

GENERAL TOLERANCE		ALL LINK CONN. TECHNOLOGY CORP.	
X±	X.*± 1°	TITLE: USB AF侧插90°成品 (内扣)	
.X± 0.30	.X.*±		
.XX± 0.20	.XX.*±		
.XXX± 0.10	.XXX.*±	PART NO. TUB-1F0411-1	DWG NO. 20120418
CUSTOMER DRAWING		APPROVED Kevin	CHECKED: Paul
UNF		DRAWN: frank	SCALE: 1:1
UNIT		mm	SHEET: 1 / 1
PROJ.		REV	B